

# Power Converter Systems

Graduate Course EE8407

Bin Wu PhD, PEng

Professor  
ELCE Department  
Ryerson University

## Contact Info

Office: ENG328  
Tel: (416) 979-5000 ext: 6484  
Email: [bwu@ee.ryerson.ca](mailto:bwu@ee.ryerson.ca)  
<http://www.ee.ryerson.ca/~bwu/>



Ryerson Campus

Textbook: Bin Wu, 'High-Power Converters and AC Drives', Wiley - IEEE Press, 2006, ISBN: 0-471-73171-4

1

EE8407

## Topic 3

### Multi-pulse Diode Rectifiers

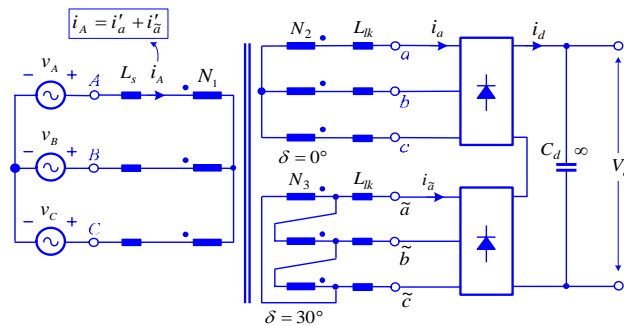

Textbook: Bin Wu, 'High-Power Converters and AC Drives', Wiley - IEEE Press, 2006, ISBN: 0-471-73171-4

2

## Multi-pulse Diode Rectifiers

---

### Lecture Topics

- **Six-pulse Diode Rectifier (Building Block)**
- **Series-type 12-, 18- and 24-pulse rectifiers**
- **Separate-type 12-, and 18-pulse rectifiers**

## Multi-pulse Diode Rectifiers

---

### Why Use Multipulse Diode Rectifiers?

- **To reduce line THD;**
- **To improve input power factor; and**
- **To avoid semiconductor devices in series.**

## Six-pulse Diode Rectifier

### • Resistive Load

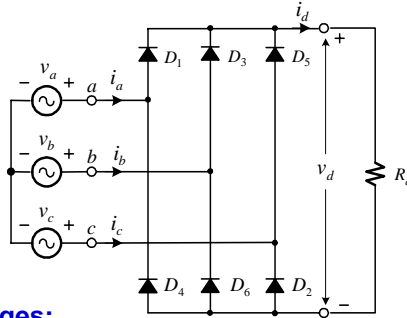

#### Supply Voltages:

$$v_a = \sqrt{2}V_{PH} \sin(\omega t)$$

$$v_b = \sqrt{2}V_{PH} \sin(\omega t - 2\pi/3)$$

$$v_c = \sqrt{2}V_{PH} \sin(\omega t - 4\pi/3)$$

$$v_{ab} = v_a - v_b = \sqrt{2}V_{LL} \sin(\omega t + \pi/6)$$

## Six-pulse Diode Rectifier

### • Waveforms

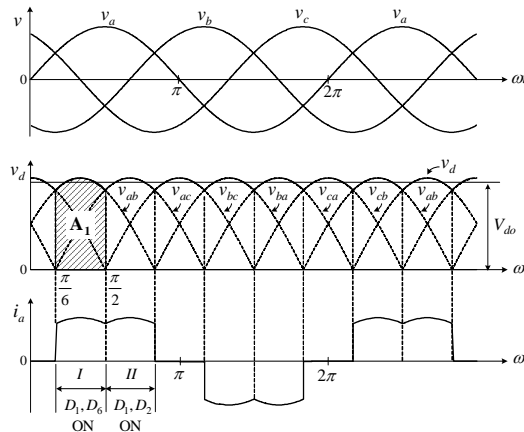

$$V_{do} = \frac{\text{area } A_1}{\pi/3} = \frac{1}{\pi/3} \int_{\pi/6}^{\pi/2} \sqrt{2}V_{LL} \sin(\omega t + \pi/6) d(\omega t) = \frac{3\sqrt{2}}{\pi} V_{LL} \approx 1.35V_{LL}$$

## Six-pulse Diode Rectifier

### • Capacitive Load

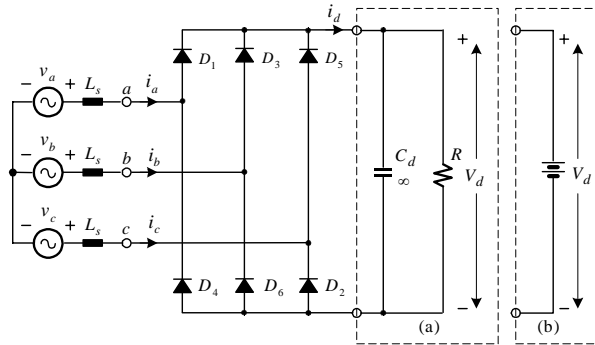

#### Assumption:

$$C_d = \infty \Rightarrow V_d = \text{constant}$$

## Six-pulse Diode Rectifier

### • Waveforms

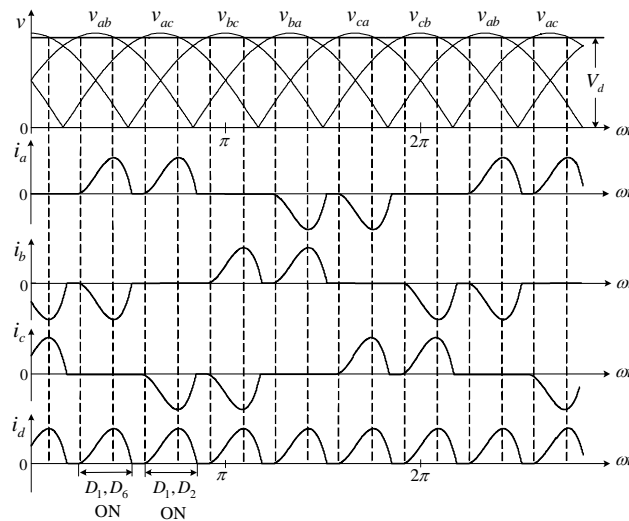

## Six-pulse Diode Rectifier

### • Discontinuous Current Operation

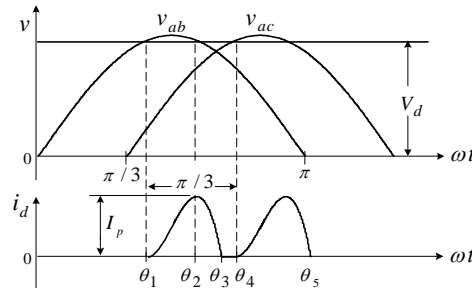

$$\theta_1 = \sin^{-1}\left(\frac{V_d}{\sqrt{2}V_{LL}}\right)$$

$$\theta_2 = \pi - \theta_1$$

Textbook: Bin Wu, 'High-Power Converters and AC Drives', Wiley - IEEE Press, 2006, ISBN: 0-471-73171-4

9

## Six-pulse Diode Rectifier

### • Discontinuous Current Operation

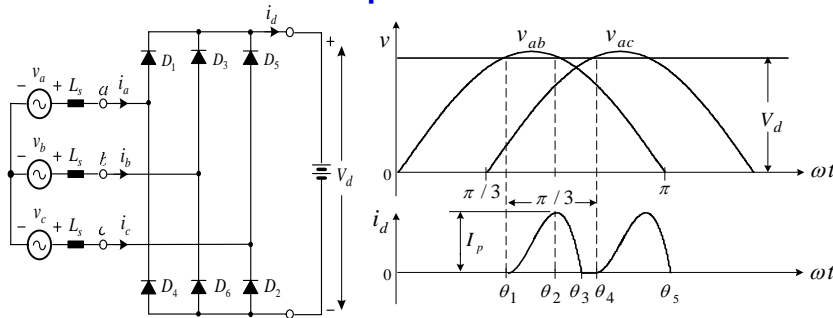

**Differential Equation:**  $2L_s \frac{di_d}{dt} = v_{ab} - V_d \quad \theta_1 \leq \omega t < \theta_3$

**Solution:** 
$$i_d(\theta) = \frac{1}{2\omega L_s} \int_{\theta_1}^{\theta} (\sqrt{2}V_{LL} \sin(\omega t) - V_d) d(\omega t)$$

$$= \frac{1}{2\omega L_s} (\sqrt{2}V_{LL} (\cos \theta_1 - \cos \theta) + V_d (\theta_1 - \theta))$$

Textbook: Bin Wu, 'High-Power Converters and AC Drives', Wiley - IEEE Press, 2006, ISBN: 0-471-73171-4

10

## Six-pulse Diode Rectifier

### • Discontinuous Current Operation

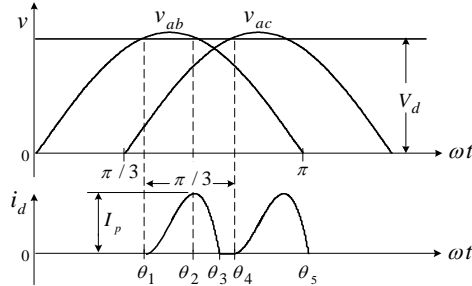

**Peak dc current:** 
$$I_p = \frac{1}{2\omega L_s} (\sqrt{2}V_{LL}(\cos\theta_1 - \cos\theta_2) + V_d(\theta_1 - \theta_2))$$

**Average dc current:** 
$$I_d = \frac{1}{\pi/3} \int_{\theta_1}^{\theta_3} i_d(\theta) d(\theta)$$

**Voltage – theta relation:** 
$$\frac{V_d}{\sqrt{2}V_{LL}} = \frac{\cos\theta_1 - \cos\theta_3}{\theta_1 - \theta_3}$$

Textbook: Bin Wu, 'High-Power Converters and AC Drives', Wiley - IEEE Press, 2006, ISBN: 0-471-73171-4

## Six-pulse Diode Rectifier

### • Continuous Current Operation

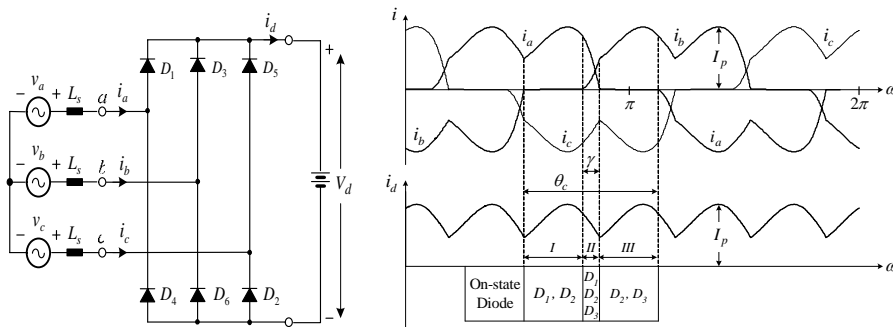

**Note:**

- With the increase of the load current, the rectifier will enter into continuous current operation.
- During commutation interval, three diodes are on.

Textbook: Bin Wu, 'High-Power Converters and AC Drives', Wiley - IEEE Press, 2006, ISBN: 0-471-73171-4

## Six-pulse Diode Rectifier

### • Definition of Total Harmonic Distortion (THD)

**Phase voltage (pure sine):**  $v_a = \sqrt{2} V_a \sin \omega_1 t$

**Line current (distorted):**  $i_a = \sum_{n=1,2,3,\dots}^{\infty} \sqrt{2} I_{an} (\sin(\omega_n t) - \phi_n)$

**RMS line current:**  $I_a = \left( \frac{1}{2\pi} \int_0^{2\pi} (i_a)^2 d(\omega t) \right)^{1/2} = \left( \sum_{n=1,2,3,\dots}^{\infty} I_{an}^2 \right)^{1/2}$

**Line current THD:**  $THD = \frac{\sqrt{I_a^2 - I_{a1}^2}}{I_{a1}}$

## Six-pulse Diode Rectifier

### • Definition of Power Factor (PF)

**Per-phase average (real) power:**  $P = \frac{1}{2\pi} \int_0^{2\pi} v_a \times i_a d(\omega t) = V_a I_{a1} \cos \phi_1$

**Per-phase apparent power:**  $S = V_a I_a$

**Total power factor (PF):**  $PF = \frac{P}{S} = \frac{V_a I_{a1} \cos \phi_1}{V_a I_a} = \frac{I_{a1}}{I_a} \cos \phi_1 = DF \times DPF$

**Distortion factor (DF):**  $DF = I_{a1} / I_a$

**Displacement power factor (DPF):**  $DPF = \cos \phi_1$

**PF = f(THD):**  $PF = \frac{DPF}{\sqrt{1 + THD^2}}$

## Six-pulse Diode Rectifier

### • Per Unit System

Rated power, rated line-to-line voltage:  $S_R, V_R$

Base voltage and frequency:  $V_B = \frac{V_R}{\sqrt{3}}$  and  $\omega_B = 2\pi f_1$

Base current and impedance:  $I_B = \frac{S_R}{3V_B}$  and  $Z_B = \frac{V_B}{I_B}$ .

Base inductance and capacitance:  $L_B = \frac{Z_B}{\omega_B}$  and  $C_B = \frac{1}{\omega_B Z_B}$

#### Example

Rectifier ratings: 4160V, 60Hz, 2MVA.

Base current = 277.6A, Base inductance = 22.9mH.

Line inductance = 2.29mH = 0.1pu

Line current = 138.8A = 0.5pu

## Six-pulse Diode Rectifier

### • Typical Waveforms / Harmonic Content

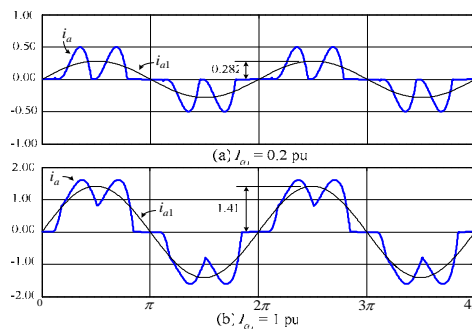

Harmonics $n$	5	7	11	13	17	19	23	25	THD (%)
$I_{an} / I_{a1}$ (%) $I_{a1} = 0.2 \text{ pu}$	63.4	38.7	8.99	8.64	4.22	3.61	2.48	2.02	75.7
$I_{an} / I_{a1}$ (%) $I_{a1} = 1 \text{ pu}$	30.4	8.79	6.31	3.40	2.30	1.89	1.04	1.03	32.7

## Six-pulse Diode Rectifier

### • THD and PF

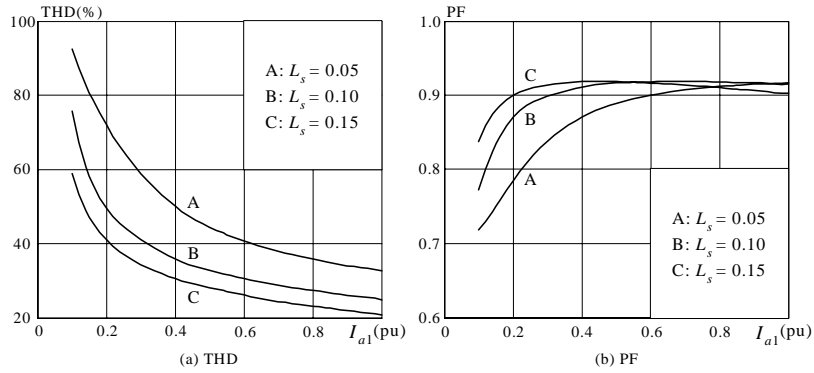

Textbook: Bin Wu, 'High-Power Converters and AC Drives', Wiley - IEEE Press, 2006, ISBN: 0-471-73171-4

17

## 12-pulse Series-type Diode Rectifier

### • Rectifier Topology

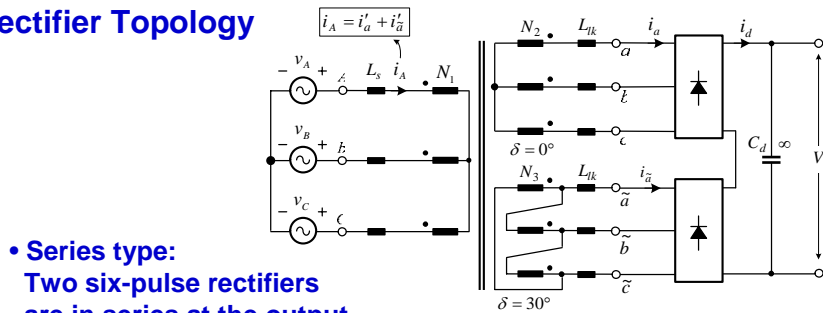

• **Series type:**  
 Two six-pulse rectifiers  
 are in series at the output.

• **Phase shifting transformer:**  $\delta = \angle V_{\bar{a}\bar{b}} - \angle V_{AB} = 30^\circ$

• **Secondary line-to-line voltage:**  $V_{ab} = V_{\bar{a}\bar{b}} = V_{AB} / 2$

• **Turns ratio:**  $\frac{N_1}{N_2} = 2$  and  $\frac{N_1}{N_3} = \frac{2}{\sqrt{3}}$ .

Textbook: Bin Wu, 'High-Power Converters and AC Drives', Wiley - IEEE Press, 2006, ISBN: 0-471-73171-4

18

# 12-pulse Series-type Diode Rectifier

## • Simplified Block Diagram

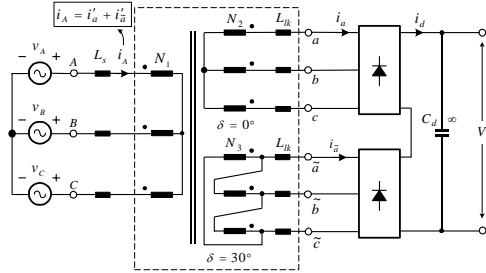

(a) 12-pulse diode rectifier

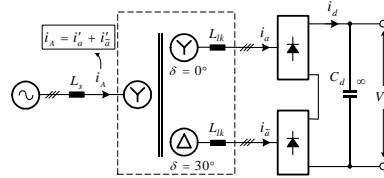

(b) Simplified diagram

Textbook: Bin Wu, 'High-Power Converters and AC Drives', Wiley - IEEE Press, 2006, ISBN: 0-471-73171-4

# 12-pulse Series-type Diode Rectifier

## • Waveforms and FFT

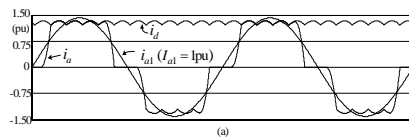

(a)

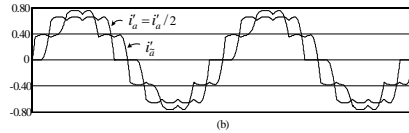

(b)

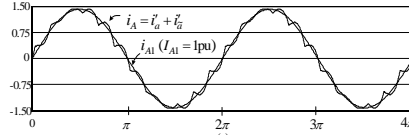

(c)

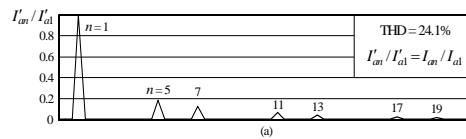

(a)

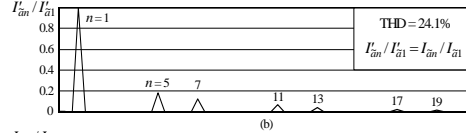

(b)

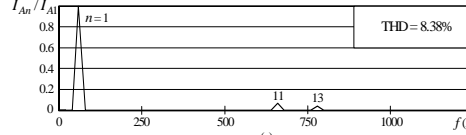

(c)

- No 5<sup>th</sup> or 7<sup>th</sup> harmonics in the line current.
- Primary line current THD: 8.38%

Textbook: Bin Wu, 'High-Power Converters and AC Drives', Wiley - IEEE Press, 2006, ISBN: 0-471-73171-4

## 12-pulse Series-type Diode Rectifier

### • THD and PF

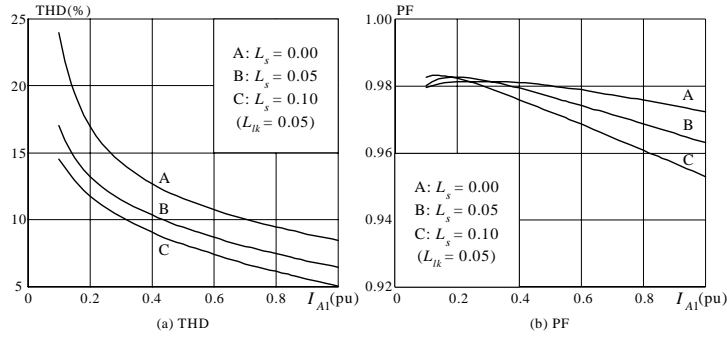

Comparison with six-pulse rectifier:

- THD is reduced; and
- PF is improved.

## 18-pulse Series-type Diode Rectifier

### • Converter Topology

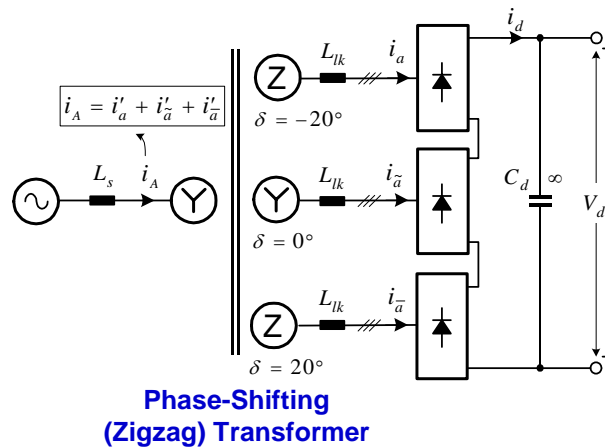

Phase-Shifting (Zigzag) Transformer

## 18-pulse Series-type Diode Rectifier

### • Simulated Waveforms

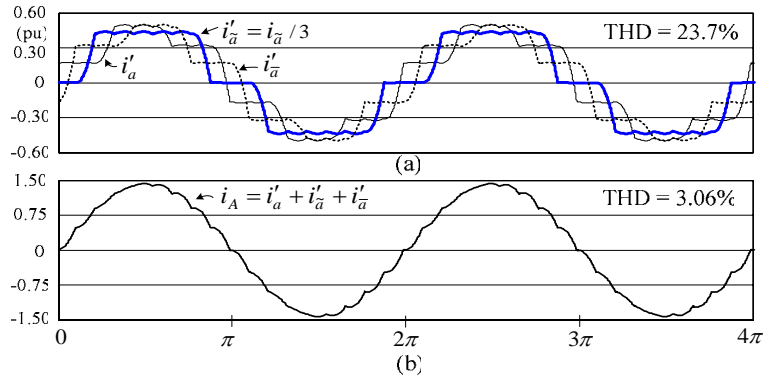

- No 5<sup>th</sup>, 7<sup>th</sup>, 11<sup>th</sup>, or 13<sup>th</sup> harmonics in the line current.
- Lowest harmonic: 17<sup>th</sup>
- Line current THD: 3.06%

Textbook: Bin Wu, 'High-Power Converters and AC Drives', Wiley - IEEE Press, 2006, ISBN: 0-471-73171-4

23

## 18-pulse Series-type Diode Rectifier

### • Measured Waveforms

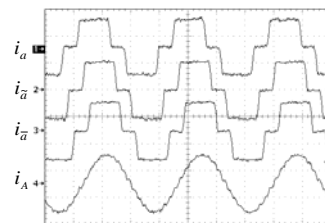

(a) Currents  $\sqrt{2}$  pu/div, 5ms/div

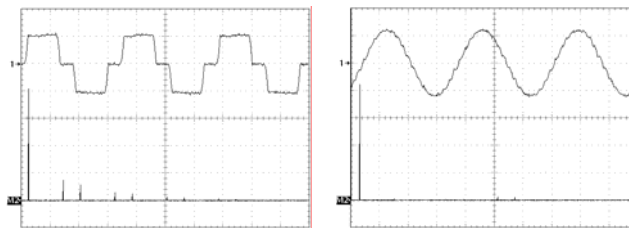

(b) Spectrum:  $\sqrt{2}/5$  pu/div, 200Hz/div

Textbook: Bin Wu, 'High-Power Converters and AC Drives', Wiley - IEEE Press, 2006, ISBN: 0-471-73171-4

24

## 18-pulse Series-type Diode Rectifier

### • THD and PF

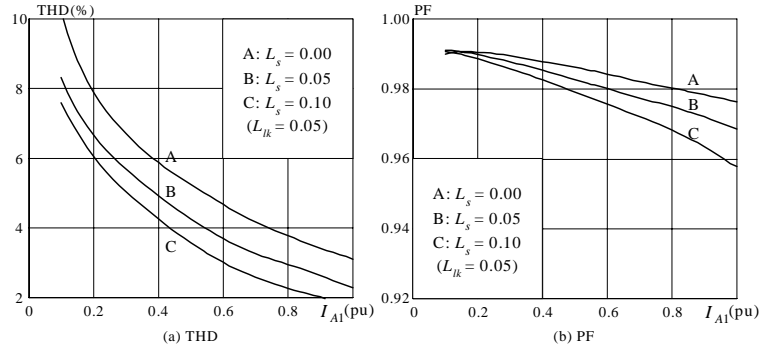

Comparison with 12-pulse:  
Improved THD

## 24-pulse Series-type Diode Rectifier

### • Converter Topology

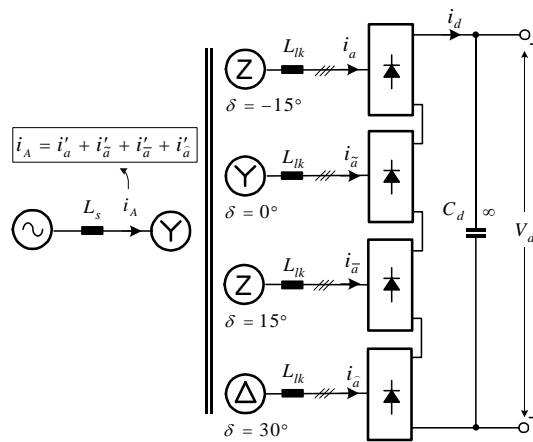

Phase-Shifting  
(Zigzag) Transformer

## 24-pulse Series-type Diode Rectifier

### • Typical Waveforms

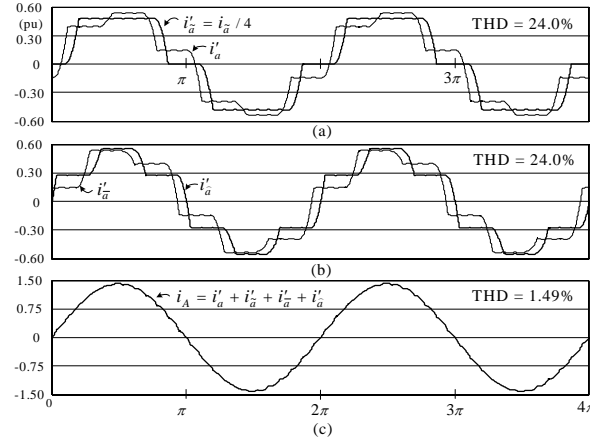

- Lowest line current harmonic: 23<sup>th</sup>
- THD: 1.49%

Textbook: Bin Wu, 'High-Power Converters and AC Drives', Wiley - IEEE Press, 2006, ISBN: 0-471-73171-4

## 24-pulse Series-type Diode Rectifier

### • THD and PF

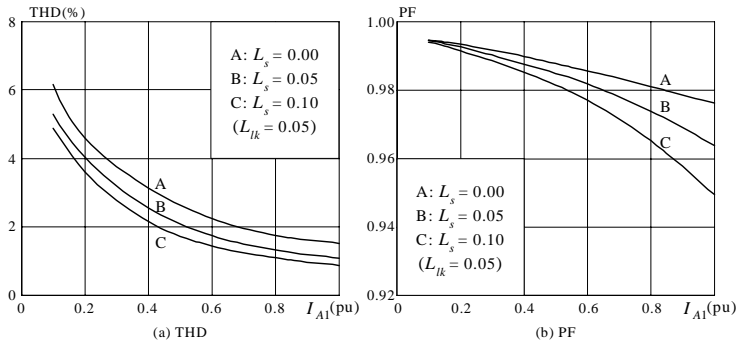

Textbook: Bin Wu, 'High-Power Converters and AC Drives', Wiley - IEEE Press, 2006, ISBN: 0-471-73171-4

## 12-pulse Separate-type Diode Rectifier

### • Rectifier Topology

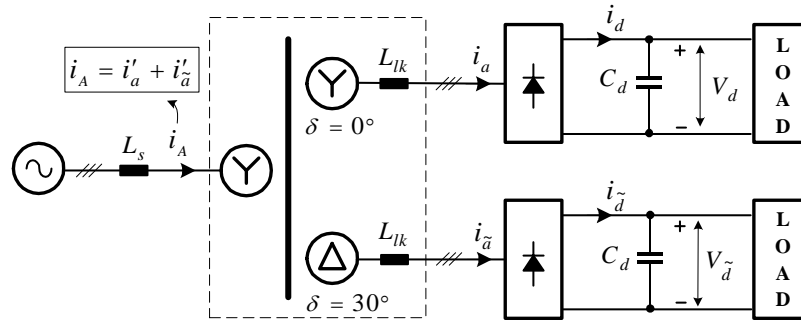

- **Separate Type**  
Each six-pulse rectifier feeds a separate dc load.

## 12-pulse Separate-type Diode Rectifier

### • Application Example

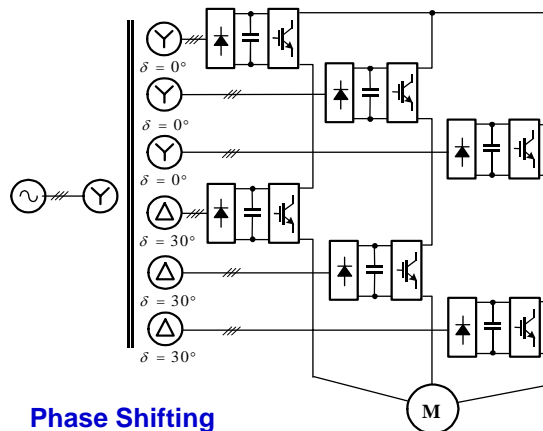

**Phase Shifting Transformer**

**Multilevel Cascade H-bridge Inverter Fed Drive**

## 12-pulse Separate-type Diode Rectifier

### • Typical Waveforms

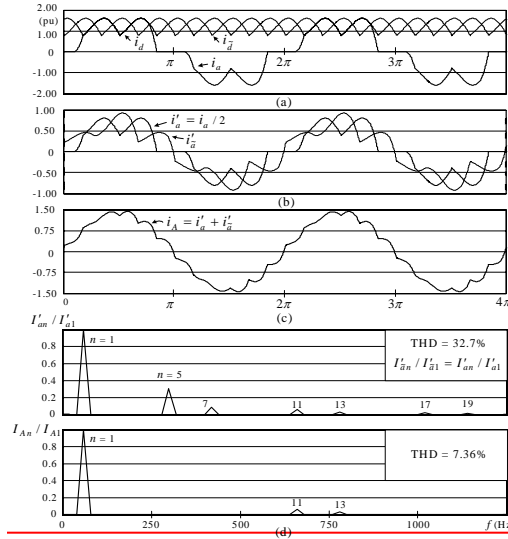

- Comparison with series-type:
  - DC current ripple: higher
  - Line current THD: close

Textbook: Bin Wu, 'High-Power Converters and AC Drives', Wiley - IEEE Press, 2006, ISBN: 0-471-73171-4

## 12-pulse Separate-type Diode Rectifier

### • Line Current THD and Input PF

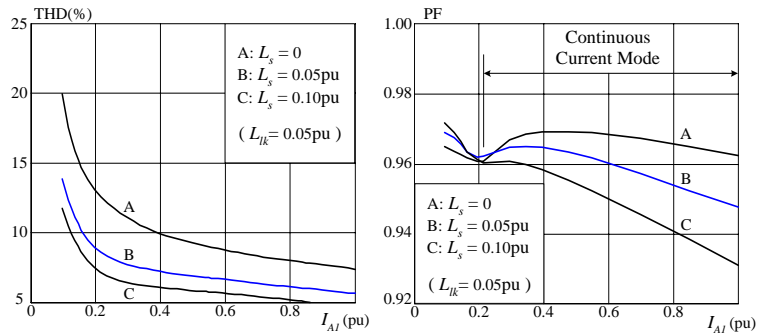

Textbook: Bin Wu, 'High-Power Converters and AC Drives', Wiley - IEEE Press, 2006, ISBN: 0-471-73171-4

## 18-pulse Separate-type Diode Rectifier

### • Rectifier Topology

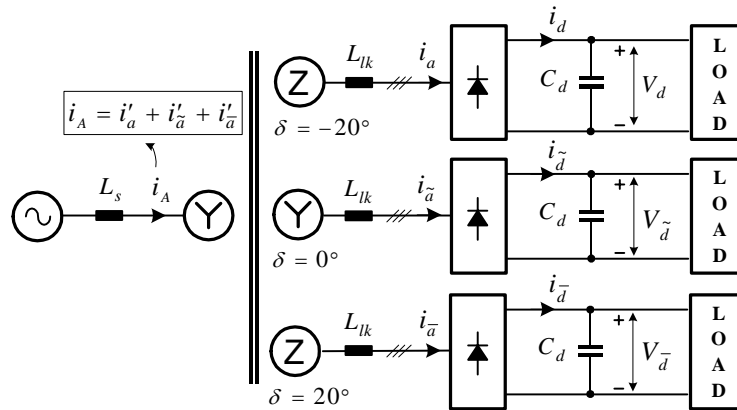

Textbook: Bin Wu, 'High-Power Converters and AC Drives', Wiley - IEEE Press, 2006, ISBN: 0-471-73171-4

33

## 18-pulse Separate-type Diode Rectifier

### • Simulated Waveforms

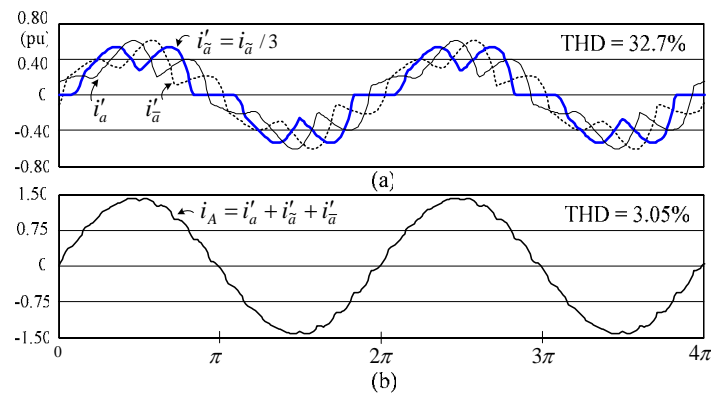

Textbook: Bin Wu, 'High-Power Converters and AC Drives', Wiley - IEEE Press, 2006, ISBN: 0-471-73171-4

34

## 18-pulse Separate-type Diode Rectifier

### • Measured Waveforms

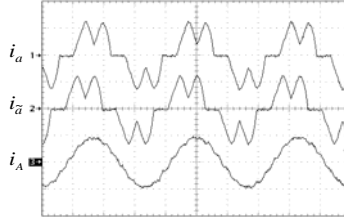

(a) Currents  $\sqrt{2}$  pu/div, 5ms/div

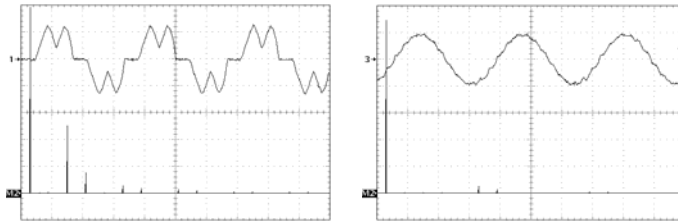

(b) Spectrum:  $\sqrt{2}/10$  pu/div, 200Hz/div

Textbook: Bin Wu, 'High-Power Converters and AC Drives', Wiley - IEEE Press, 2006, ISBN: 0-471-73171-4

## 18-pulse Separate-type Diode Rectifier

### • Line Current THD and Input PF

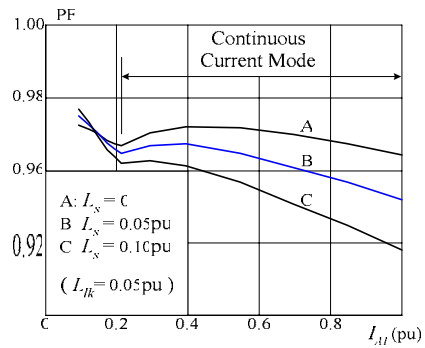
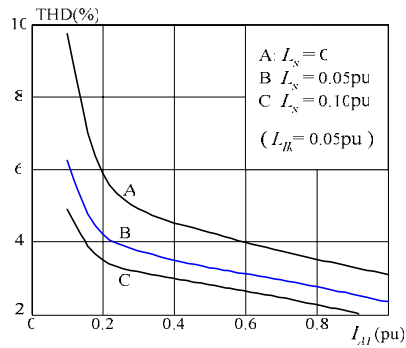

Textbook: Bin Wu, 'High-Power Converters and AC Drives', Wiley - IEEE Press, 2006, ISBN: 0-471-73171-4

## 24-pulse Separate-type Diode Rectifier

- Line Current THD and Input PF

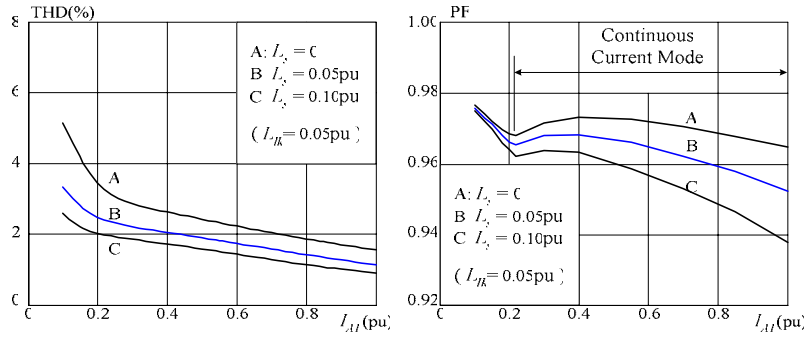

Textbook: Bin Wu, 'High-Power Converters and AC Drives', Wiley - IEEE Press, 2006, ISBN: 0-471-73171-4



Thanks